

**1**

A battery in a laptop computer has an electromotive force (emf) of 14.8 V and can store a maximum charge of  $15.5 \times 10^3$  C. The battery has negligible internal resistance.

(a) Calculate the maximum amount of energy this battery can deliver.

energy \_\_\_\_\_ J

**(2)**

(b) The average power consumption of the laptop is 30 W.

Estimate how long the laptop can be operated from the fully charged battery. Give your answer in hours.

time \_\_\_\_\_ hours

**(2)**

**(Total 4 marks)**

**2**

**X** and **Y** are two lamps. **X** is rated at 12 V 36 W and **Y** at 4.5 V 2.0 W.

(a) Calculate the current in each lamp when it is operated at its correct working voltage.

**X** \_\_\_\_\_ A

**Y** \_\_\_\_\_ A

**(2)**

- (b) The two lamps are connected in the circuit shown in the figure below. The battery has an emf of 24 V and negligible internal resistance. The resistors,  $R_1$  and  $R_2$  are chosen so that the lamps are operating at their correct working voltage.

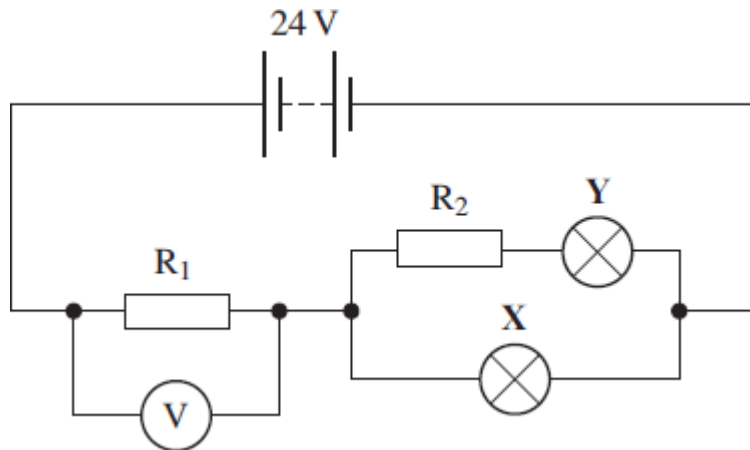

- (i) Calculate the pd across  $R_1$ .

answer \_\_\_\_\_ V

(1)

- (ii) Calculate the current in  $R_1$ .

answer \_\_\_\_\_ A

(1)

- (iii) Calculate the resistance of  $R_1$ .

answer \_\_\_\_\_  $\Omega$

(1)

- (iv) Calculate the pd across  $R_2$ .

answer \_\_\_\_\_ V

(1)

- (v) Calculate the resistance of  $R_2$ .

answer \_\_\_\_\_  $\Omega$

(1)

(c) The filament of the lamp in **X** breaks and the lamp no longer conducts. It is observed that the voltmeter reading decreases and lamp **Y** glows more brightly.

(i) Explain without calculation why the voltmeter reading decreases.

---

---

---

(2)

(ii) Explain without calculation why the lamp **Y** glows more brightly.

---

---

---

(2)

(Total 11 marks)

**3**

A car battery has an emf of 12 V and an internal resistance of  $9.5 \times 10^{-3} \Omega$ . When the battery is used to start a car the current through the battery is 420 A.

(a) Calculate the voltage across the terminals of the battery, when the current through the battery is 420 A.

---

---

---

---

answer \_\_\_\_\_ V

(2)

- (b) The copper cable connecting the starter motor to the battery has a length of 0.75 m and cross-sectional area of  $7.9 \times 10^{-5} \text{ m}^2$ . The resistance of the cable is  $1.6 \times 10^{-3} \Omega$ .

Calculate the resistivity of the copper giving an appropriate unit.

---



---



---



---



---



---

answer \_\_\_\_\_

(3)

(Total 5 marks)

4

A battery of emf 24 V and negligible internal resistance is connected to a resistor network as shown in the circuit diagram in the diagram below.

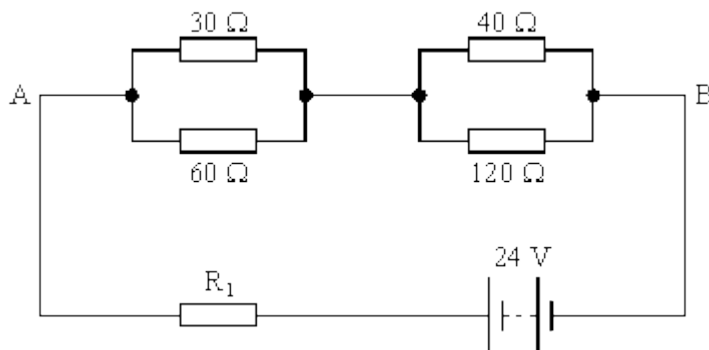

- (a) Show that the resistance of the single equivalent resistor that could replace the four resistors between the points A and B is  $50 \Omega$ .

---



---



---



---



---



---

(4)

(b) If  $R_1$  is  $50\ \Omega$ , calculate

(i) the current in  $R_1$ ,

---

---

(ii) the current in the  $60\ \Omega$  resistor.

---

---

---

(4)  
(Total 8 marks)

5

The diagram below shows part of an electrical circuit where **five** wires form a junction. The electric currents are shown on the figure.

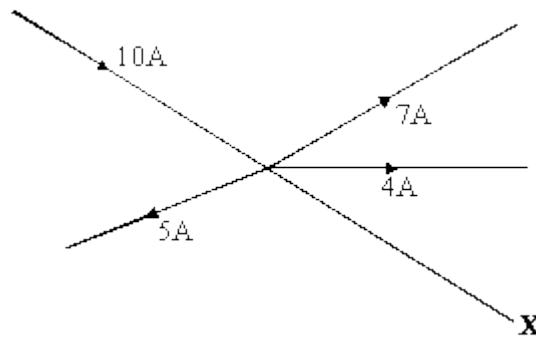

State the size of the current in wire **X**. Draw an arrow on the diagram to indicate the direction of the current.

Current \_\_\_\_\_

(Total 2 marks)

6

A filament lamp rated 12 V, 1.0 A has a resistance of  $4.0 \Omega$  when it carries no current.

(a) On the axes below, sketch the form of the current against voltage characteristic for this lamp.

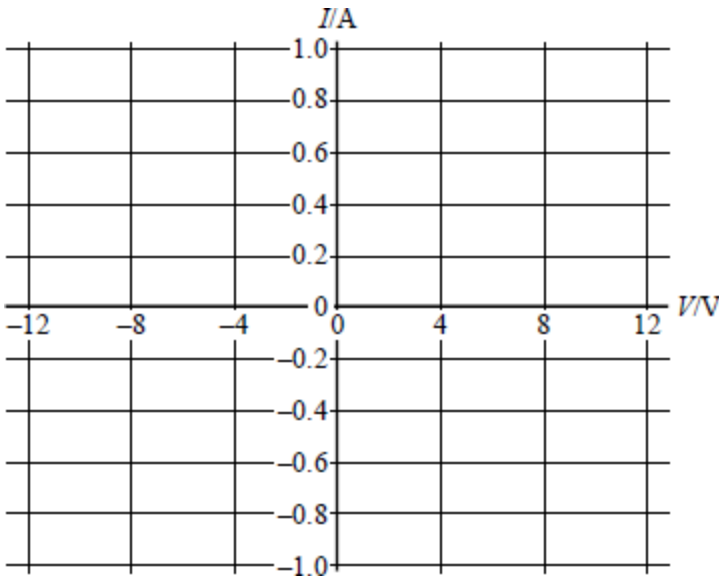

(4)

(b) The filament lamp is one example of a *non-ohmic* device.

(i) State what is meant by the term *non-ohmic*.

---

---

(ii) Name **one** other example of a *non-ohmic* device.

---

(2)

(Total 6 marks)

7

A 'potato cell' is formed by inserting a copper plate and a zinc plate into a potato. The circuit shown in **Figure 1** is used in an investigation to determine the electromotive force and internal resistance of the potato cell.

Figure 1

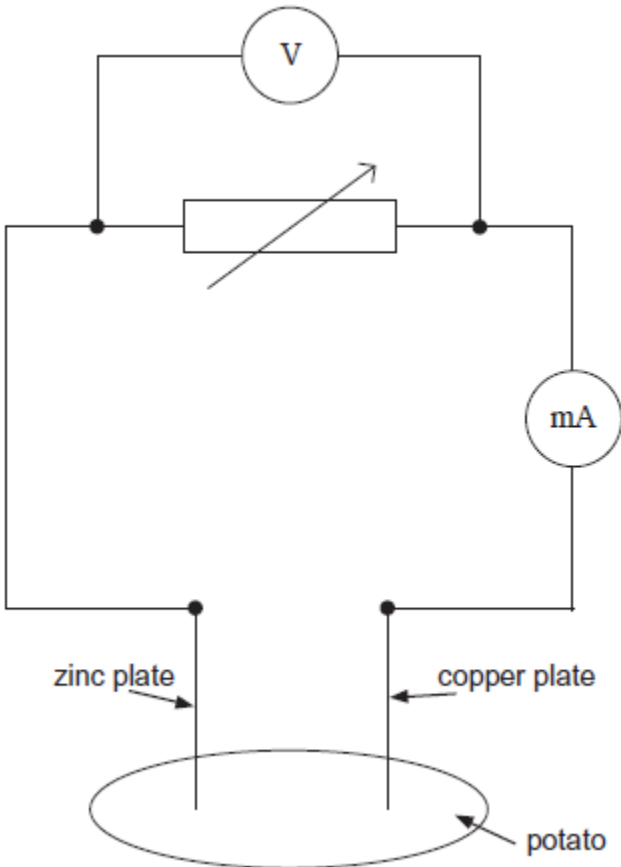

(a) State what is meant by electromotive force.

---

---

---

---

(2)

- (b) The plotted points on **Figure 2** show the data for current and voltage that were obtained in the investigation.

**Figure 2**

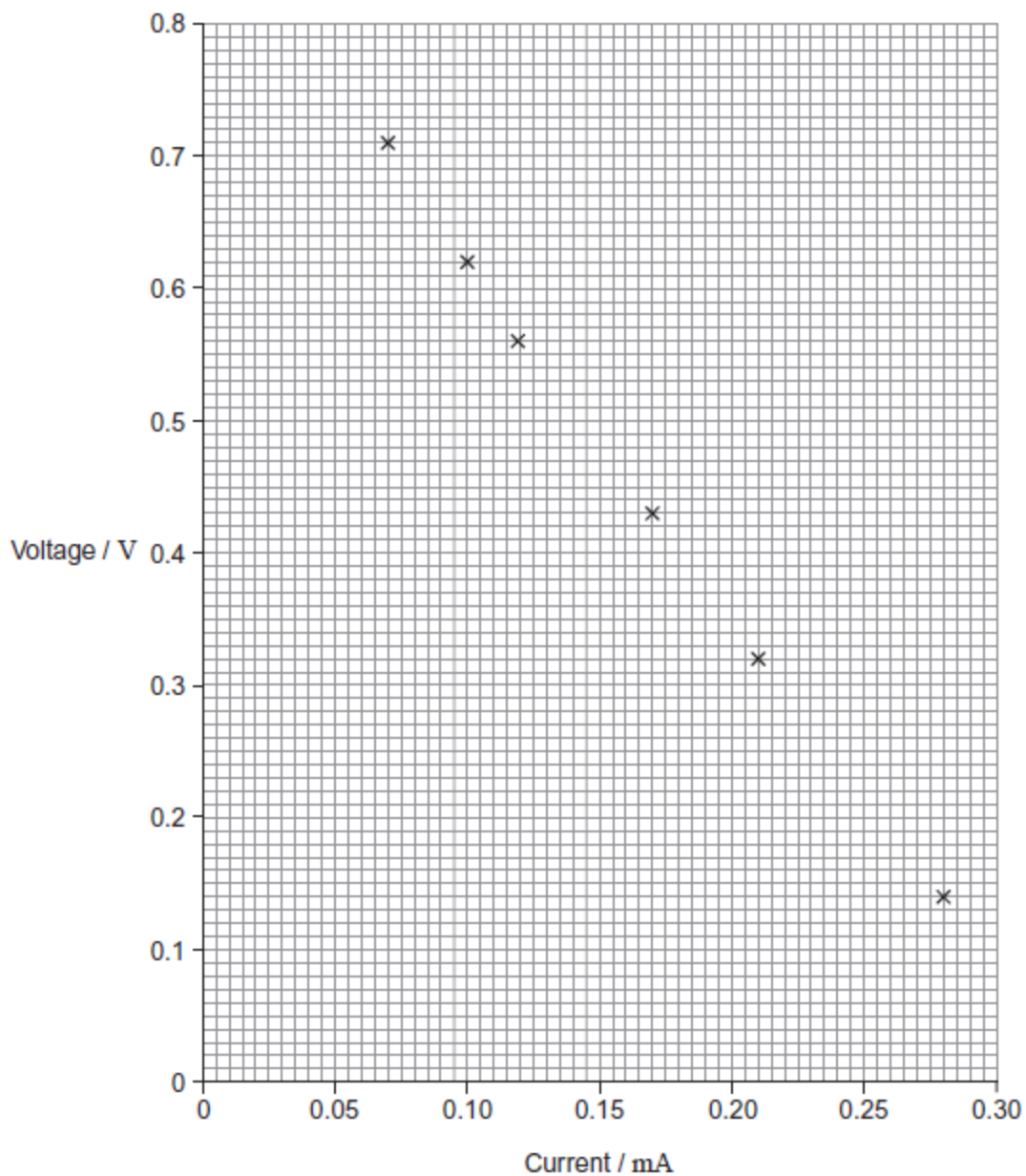

- (i) Suggest what was done to obtain the data for the plotted points.

---

---

---

---

(1)



- (ii) The electromotive force (emf) of the potato cell is 0.89 V. Explain why the voltages plotted on **Figure 2** are always less than this and why the difference between the emf and the plotted voltage becomes larger with increasing current.

---

---

---

---

---

---

---

---

(3)

- (iii) Use **Figure 2** to determine the internal resistance of the potato cell.

internal resistance = \_\_\_\_\_  $\Omega$

(3)

- (c) A student decides to use two potato cells in series as a power supply for a light emitting diode (LED). In order for the LED to work as required, it needs a voltage of at least 1.6 V and a current of 20 mA.

Explain whether the LED will work as required.

---

---

---

---

---

---

---

(2)

(Total 11 marks)

8

(a) Show that the unit of resistivity is  $\Omega \text{ m}$ .

---

---

(1)

(b) A cable consists of seven straight strands of copper wire each of diameter 1.35 mm as shown in the diagram.

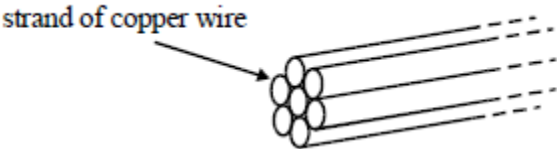

Calculate

(i) the cross-sectional area of **one strand** of copper wire,

---

---

(ii) the resistance of a 100 m length of the **cable**, given that the resistivity of copper is  $1.6 \times 10^{-8} \Omega \text{ m}$ .

---

---

---

---

(4)

(c) (i) If the cable in part (b) carries a current of 20 A, what is the potential difference between the ends of the cable?

---

---

---

---

(ii) If a single strand of the copper wire in part (b) carried a current of 20 A, what would be the potential difference between its ends?

---

---

(2)

- (d) State **one** advantage of using a stranded rather than a solid core cable with copper of the same total cross-sectional area.

---

(1)

(Total 8 marks)

9

- (a) A sample of conducting putty is rolled into a cylinder which is  $6.0 \times 10^{-2}$  m long and has a radius of  $1.2 \times 10^{-2}$  m.

resistivity of the putty =  $4.0 \times 10^{-3}$   $\Omega$ m.

Calculate the resistance between the ends of the cylinder of conducting putty.  
Your answer should be given to an appropriate number of significant figures.

answer = \_\_\_\_\_  $\Omega$

(4)

(b) Given the original cylinder of the conducting putty described in part (a), describe how you would use a voltmeter, ammeter and other standard laboratory equipment to determine a value for the resistivity of the putty.

Your description should include

- a labelled circuit diagram,
- details of the measurements you would make,
- an account of how you would use your measurements to determine the result,
- details of how to improve the precision of your measurements.

The quality of your written communication will be assessed in this question.

---

---

---

---

---

---

---

---

---

---

---

**(8)**  
**(Total 12 marks)**

**10**

When the temperature of a copper wire increases, its ability to conduct electricity

- A remains the same.
- B increases.
- C decreases.
- D remains the same at first and then increases.

(Total 1 mark)

**11**

The overhead cables used to transmit electrical power by the National Grid usually consist of a central core of steel cables surrounded by a sheath of cables of low resistivity material, such as aluminium.

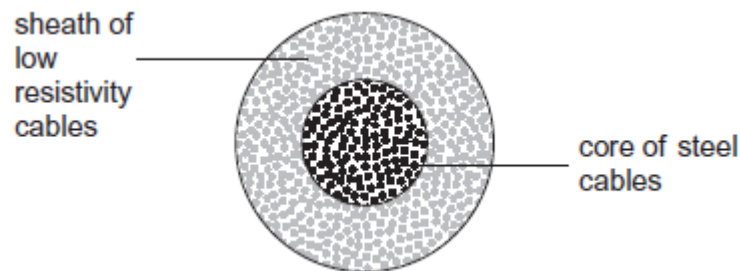

What is the main purpose of the steel core?

- A To force more current into the outer sheath.
- B To provide additional current paths through the cables.
- C To reduce the power lost from the cables.
- D To increase the mechanical strength of the cables.

(Total 1 mark)

**12**

A 1.5 m length of wire has a cross-sectional area  $5.0 \times 10^{-8} \text{ m}^2$ . When the potential difference across its ends is 0.20 V, it carries a current of 0.40 A. The resistivity of the material from which the wire is made is

- A  $6.0 \times 10^7 \Omega \text{ m}$
- B  $1.7 \times 10^{-8} \Omega \text{ m}$
- C  $1.1 \times 10^6 \Omega \text{ m}$
- D  $9.4 \times 10^{-7} \Omega \text{ m}$

(Total 1 mark)

13

A metal wire is maintained at a constant temperature. Which one of the following graphs best represents the relationship between the dissipated power  $P$  and the current  $I$  in the wire?

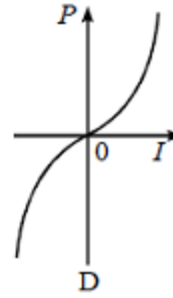
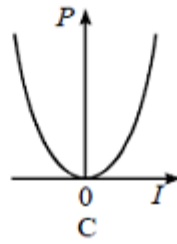
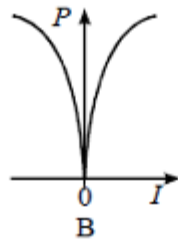
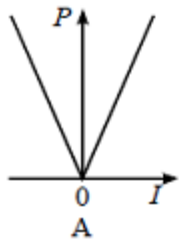

(Total 1 mark)

14

The diagram shows two wires, **P** and **Q**, of equal length, joined in series with a cell. A voltmeter is connected between the end of **Q** and a point **X** on the wires. The p.d. across the cell is  $V$ . Wire **Q** has twice the area of cross-section and twice the resistivity of wire **P**. The variation of the voltmeter reading as the point **X** is moved along the wires is best shown by

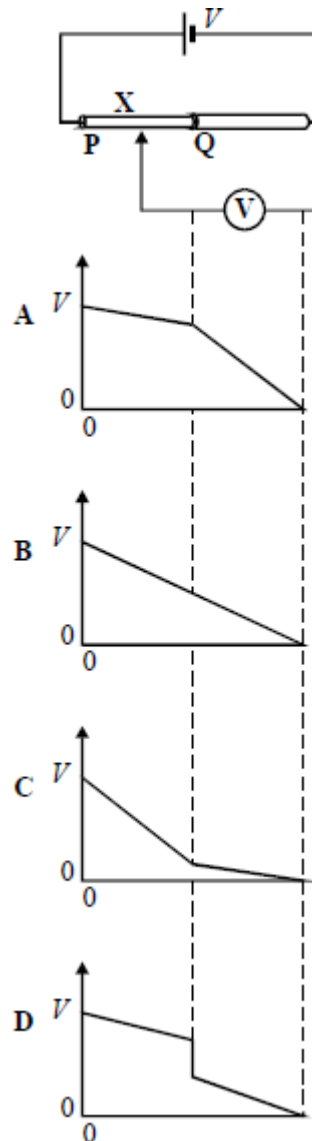

(Total 1 mark)

15 Copper metal is a good conductor of electricity because copper atoms in copper metal

- A have gained an extra or “free” electron
- B are ionised so that both ions and “free” electrons can move
- C have a negative charge because of the “free” electrons
- D have lost an electron to form positive ions and “free” electrons

(Total 1 mark)

16 Two resistors  $R_1$  and  $R_2$  are made of wires of the same material. The wire used for  $R_1$  has half the diameter and is twice as long as the wire used for  $R_2$ .

What is the value of the ratio  $\frac{\text{resistance of } R_1}{\text{resistance of } R_2}$ ?

- A 8
- B 4
- C 1
- D 0.5

(Total 1 mark)

17 The diagram shows a network of four  $2\ \Omega$  resistors.

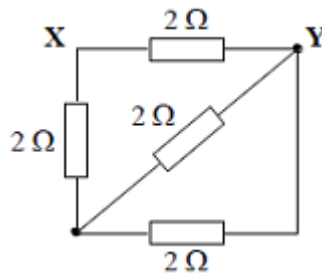

The effective resistance, in  $\Omega$ , between **X** and **Y** is

- A 0.5
- B 1.2
- C 1.7
- D 2.0

(Total 1 mark)

**18**

A  $1.0 \text{ k}\Omega$  resistor is thermally insulated and a potential difference of  $6.0 \text{ V}$  is applied to it for  $2.0$  minutes. The thermal capacity of the resistor is  $9.0 \text{ J K}^{-1}$ . The rise in temperature, in  $\text{K}$ , is

- A  $1.3 \times 10^{-3}$
- B  $8.0 \times 10^{-3}$
- C  $0.48$
- D  $0.80$

**(Total 1 mark)**



## Mark schemes

**1**

(a) use of  $\epsilon = E / V$

*condone power 10 errors in sub*

*allow rearrangement to  $E = \epsilon V$*

*$14.8 \times 15.5 \times 10^3$  seen*

C1

$$2.29 \times 10^5 \text{ (J)} / 2.3 \times 10^5 \text{ (J)}$$

A1

2

(b) use of  $P = \Delta W / \Delta t$

*condone power 10 errors in sub*

*Allow rearrangement to  $\Delta t = \Delta W / P$   $2.3 \times 10^5 / 30$  or*

*7647 seen*

C1

2.12 (hours) cao

A1

2

[4]

**2**

(a) (use of  $P = VI$ )

$$I = 36/12 = 3.0 \text{ A } \checkmark$$

$$I = 2.0/4.5 = 0.44 \text{ A } \checkmark$$

2

(b) (i) pd = 24 - 12 = 12 V  $\checkmark$

1

(ii) current = 3.0 + 0.44 = 3.44 A  $\checkmark$

1

(iii)  $R_1 = 12/3.44 = 3.5 \Omega \checkmark$

1

(iv) pd = 12 - 4.5 - 7.5 V  $\checkmark$

1

(v)  $R_2 = 7.5/0.44 = 17 \Omega \checkmark$

1

- (c) (i) (circuit) resistance increases ✓  
 current is lower (reducing voltmeter reading) ✓  
 or correct potential divider argument

2

- (ii) pd across Y or current through Y increases ✓  
 hence power/rate of energy dissipation greater or temperature of lamp increases ✓

2

[11]

3

- (a) (use of  $E = V + Ir$ )

$$12 = V + 420 \times 0.0095 \text{ (1)}$$

$$V = 8.0(1) \text{ V (1)}$$

2

- (b)  $\rho = RA/l = 1.6 \times 10^{-3} \times 7.9 \times 10^{-5}/0.75 \text{ (1)}$

$$R = 1.7 \times 10^{-7} \text{ (1) } \Omega\text{m (1)}$$

3

[5]

4

- (a) first pair in parallel  $\frac{1}{R'} = \frac{1}{30} + \frac{1}{60} \text{ (1)}$

$$= \frac{3}{60} = \text{gives } R' = 20 \text{ (}\Omega\text{) (1)}$$

$$\text{second pair in parallel } \frac{1}{R''} = \frac{1}{40} + \frac{1}{120} \text{ gives } R'' = 30(\Omega) \text{ (1)}$$

$$\text{resistance between A and B} = 20 + 30 \text{ (1) (= 50 } \Omega\text{)}$$

(allow C.E. for values of  $R$  and  $R''$ )

4

- (b) (i) total resistance =  $50 + 50 = 100 \text{ } \Omega \text{ (1)}$   
 ( $V = IR$  gives)  $24 = I 100$  and  $I = 0.24 \text{ A (1)}$

(ii) current in  $60 \text{ } \Omega = \frac{1}{3} I \text{ (1)}$   
 $= 0.080 \text{ (A) (1)}$

[or alternative method]

(allow C.E. for value of  $I$  from (b)(i))

4

[8]

5 6A

M1

towards junction

A1

[2]

6 (a)

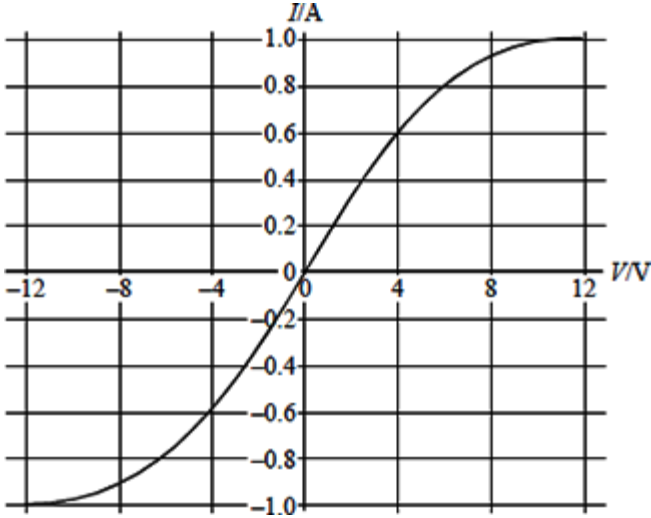

- shape in one quadrant (1)
- symmetrical (1)
- (1.0, 1.2) (1)
- (0, 0) (1)
- slope at (0, 0) (1)

(max 4)

- (b) (i)  $V$  is not directly proportional to  $I$  [or resistance is constant] (1)
- (ii) e.g. semiconductor diode (1)

(2)

[6]

7 (a)

emf is the work done / energy transferred by a voltage source / battery / cell ✓ per unit charge✓  
 OR  
 electrical energy transferred / converted / delivered / produced✓  
 per unit charge✓  
 OR  
 pd across terminals when no current flowing / open circuit✓✓

*not in battery*  
*accept word equation OR symbol equation with symbols defined if done then must explain energy / work in equation for first mark*

2

- (b) (i) by altering the (variable) resistor✓

1

- (ii) reference to correct internal resistance✓  
*e.g. resistance of potato (cell)*  
 terminal pd = emf – pd across internal resistance / lost volts✓  
 pd / lost volts increases as current increases OR as (variable)  
 resistance decreases greater proportion / share of emf across internal  
 resistance✓  
*accept voltage for pd*

3

- (iii) draws best fit straight line and attempts to use gradient✓  
 uses triangle with base at least 6 cm✓  
 value in range 2600 – 2800 (Ω)✓

3

*stand-alone last mark*

- (c) total emf is above 1.6 V✓  
 but will not work as current not high enough / less than 20 mA✓

2

[11]

8

(a)  $\rho = \frac{RA}{l} \Rightarrow \frac{\Omega m^2}{m} \Rightarrow \Omega m$

1

(b) (i)  $A = 1.43 \times 10^{-6} \text{ m}^2$  (1)

(ii)  $R_{\text{strand}} = \frac{1.6 \times 10^{-8} \times 10^2}{1.4 \times 10^{-6}} = 1.1\Omega$  (1)

$R_{\text{cable}} = \frac{1.12}{7}$  (1) = 0.16Ω (1)

*alternative (ii):*

$A = 7$  (1)  $\times 1.4 \times 10^{-6}$

substitution (1)

leading to  $R_{\text{cable}} = 0.16 \Omega$  (1)

4

(c) (i)  $V = 3.2 \text{ V}$  (1)

(ii)  $V = 7 \times 3.2 \text{ V} = 22\text{V}$  (1)

2

- (d) cable is flexible (\*)  
 one strand fails, cable continues to conduct (\*)  
 larger surface area so better heat dissipation etc (\*)  
 (\*) any one (1)

1

[8]

**9**

(a) (use of  $R = \rho l/A$ )

$$R = 4.0 \times 10^{-3} \times 0.060 \text{ (1)} / (\pi \times 0.012^2) \text{ (1)}$$

$$R = 0.53 \text{ } (\Omega) \text{ (1)}$$

2 significant figures **(1)**

4

- (b) the mark scheme for this part of the question includes an overall assessment for the Quality of Written Communication

circuit must include:

voltmeter and ammeter connected correctly **(1)**

power supply with means of varying current **(1)**

2

<b>QWC</b>	<b>descriptor</b>	<b>mark range</b>
good-excellent	<p>(i) Uses accurately appropriate grammar, spelling, punctuation and legibility.</p> <p>(ii) Uses the most appropriate form and style of writing to give an explanation or to present an argument in a well structured piece of extended writing. [may include bullet points and/or formulae or equations]</p> <p>An excellent candidate will have a working circuit diagram with correct description of measurements (including range of results) and processing. An excellent candidate uses a range of results and finds a mean value or uses a graphical method, eg <math>I</math>-<math>V</math> characteristics. They also mention precision eg use of vernier callipers.</p>	<b>5-6</b>
modest-adequate	<p>(i) Only a few errors.</p> <p>(ii) Some structure to answer, style acceptable, arguments or explanations partially supported by evidence or examples.</p> <p>An adequate candidate will have a working circuit and a description with only a few errors, eg do not consider precision. They have not taken a range of results and fail to realise that the diameter needs to be measured in several places.</p>	<b>3-4</b>
poor-limited	<p>(i) Several significant errors.</p> <p>(ii) Answer lacking structure, arguments not supported by evidence and contains limited information.</p> <p>Several significant errors, eg important measurement missed, incorrect circuit, no awareness of how to calculate resistivity.</p>	<b>1-2</b>
incorrect, inappropriate or no response		<b>0</b>

The explanation expected in a good answer should include a coherent account of the procedure and include most of the following points.

- length with a ruler
- thickness/diameter with vernier callipers/micrometer
- measure voltage
- measure current
- calculate resistance
- use of graph, eg  $I$ - $V$  or resistance against length
- use of diameter to calculate cross-sectional area
- mention of precision, eg vernier callipers or full scale readings for  $V$  and  $I$
- flat metal electrodes at each end to improve connection

6

[12]

10 C

[1]

11 D

[1]

12 B

[1]

13 C

[1]

14 B

[1]

15 D

[1]

16 A

[1]

17 B

[1]

18 C

[1]

## Examiner reports

**1** This was a straightforward question with most students being able to carry out the calculations in both parts. Part (b) posed slightly more problems with a good number of students failing to correctly convert seconds into hours. Some students failed to select an appropriate formula to use or substituted incorrectly by mixing up energy and power.

**2** With the exception of part (a), students found this question particularly challenging.

The calculations in part (b) were very structured but this did not seem make the analysis of the circuit straightforward. In part (b) (i), less than half the students were able to calculate the pd across the resistor correctly with many not appreciating that the pd across the a parallel network was the same as the pd across lamp X. Part (b) (ii) produced better answers, although a significant proportion of students did not appreciate that they simply needed to add together the two currents calculated in part (a).

Part (b) (iii) was answered well, although many students benefited from being allowed to use incorrect answers from parts (b) (i) and (ii). The remainder of the circuit analysis did cause problems due to many students not realising that the pd across  $R_2$  was simply the difference in the pd's across the lamps or that the current through  $R_2$  was the same as the current in lamp Y.

Part (c) required students to consider the effect of lamp X ceasing to conduct. In part (c) (i) they had to explain the effect on the voltmeter reading. This was not answered well with a significant proportion of students thinking the voltmeter reading would increase. This was mainly due to the mistaken assumption that the current in the circuit would increase. Part (c) (ii) generated more correct responses because many students stated that the current through lamp Y would increase, although it was clear from their answers many thought that this was due to the current from lamp X now going through lamp Y. It was not commonly appreciated that although the overall current in the circuit had decreased, the current through  $R_2$  and lamp Y was higher than it had been when lamp X was conducting.

**3** Part (a) caused similar problems to the question on emf and internal resistance in the January examination. A common, incorrect approach was to calculate the potential difference across the internal resistance and quote this as the value of terminal pd.

Part (b) proved to be much more accessible and the calculation only caused a few candidates problems. The unit for resistivity does confuse a significant proportion of candidates and this is often quoted as  $\Omega \text{ m}^{-1}$  or  $\Omega/\text{m}$ .

**4** Part (a) was the calculation of the equivalent resistance of a network of resistors consisting of resistors connected in series and in parallel. The majority of candidates gained full marks on this section and were not troubled by the calculation. However, it is worth pointing out that since the final answer of  $50 \Omega$  was given in the question, then in order to gain full marks it was necessary to show that the two equivalent series resistors were being added together.

Part (b) did not prove to be as easy; the problem in (i) was that many candidates gave the total resistance as  $50 \Omega$  rather than  $100 \Omega$ . No consequential error for calculating the current was allowed and frequently no marks were awarded for this section. It was possible in part (b)(ii) to gain the two marks even if the answer to (i) was incorrect, but very few candidates managed to gain these marks. The usual error was giving the current in the circuit as  $24/20$ , i.e. ignoring the second batch of parallel resistors. Again, many candidates, having calculated the total current correctly, assumed that  $2/3$  would pass through the  $60 \Omega$  resistor, not realising that the greater the resistor, the lower the current for a given voltage.



5 This easy question was answered well by a large majority. Even so, there was a minority of candidates who were unable to calculate the current and its direction.

6 This question produced some mixed responses and a significant proportion of the candidates did not realise that the graph in part (a) should be drawn in two quadrants. Furthermore, many candidates sketched a graph which would have been correct with reversed axes. It was clear that some were not aware what the V-I characteristic for a filament lamp should look like.

Some candidates found part (b)(i) to be confusing and statements such as “a non-ohmic conductor is one that does not follow Ohm’s law” were common. Whilst this is true, it is really only repeating the question without answering it.

7 This question required students to analyse a circuit, which included a potato cell. Initially they had to explain what is meant by the emf of a power supply. Answers to this were often vague and did not explain where energy transfer took place. When it came to explaining the results most students appreciated that the internal resistance meant that the terminal pd was less than the emf but convincing explanations as to why the difference between terminal pd and emf increased with current were rare. Many seemed to think that the internal resistance increased as the external resistance decreased. The determination of the internal resistance from the graph was not well done and a significant number of students failed to use the gradient of the graph. Many failed to realise that the current was in milliamps and so finished up with internal resistance, which were much too small.

The final part of this question required an analysis of whether two potato cells in series would enable a LED to light. Only the most able students approached this in a logical way by identifying the emf of the two cells would be 1.78 V but then appreciating that the current the cells were able to provide would be much less than 20 mA.

8 A few candidates simply quoted the unit of resistivity in part (a) without showing how it is derived from the relationship between resistance and resistivity.

In part (b)(i) the calculation of the area of a circle was beyond some candidates and it would be beneficial to make it clear to candidates that m is the unit of length,  $m^2$  is the unit of area and  $m^3$  is the unit of volume. This being the case, then the area of a circle must involve a length squared, in other words  $r^2$ . Most candidates were able to calculate the resistance of a strand of the copper wire, but some did not go on to calculate the resistance of the cable. Good candidates realised that the resistance of the cable is less than the resistance of a single strand since the strands are in parallel.

Part (c) was generally answered well, with the majority of candidates gaining the full two marks.

In part (d) there were many good answers which included the flexibility of the cable and the fact that if one strand breaks the cable will continue to conduct.

9 Part (a) proved straightforward and many candidates were able to calculate the resistance of the putty correctly. A minority of candidates did confuse resistance with resistivity and did not rearrange the equation from the data sheet. This question assessed significant figures and it was clear that there are still many candidates who do not appreciate that their final answer should reflect the precision of the data and in this case they should give their answer to two significant figures.

Part (b) assessed quality of written communication and this question proved quite challenging for the majority of candidates. It was extremely rare for candidates to obtain full marks and most answers were either modest and/or limited. The circuit diagrams seen were often penalised for careless errors such as incorrect symbols or the wrong positioning of meters.

It was rare for candidates to include a means of obtaining more than one result such as varying the length of the putty or using a variable resistor. Descriptions were often vague and hard to follow. Many candidates did not address the issue of precision in a convincing way and failed to describe how they would make all the measurements needed. It is clear from this paper and from previous papers that candidates find describing experiments difficult and would benefit from some practice of this skill.

11

The synoptic (or “common sense”) element in answering this question made the question more difficult than it really should have been. With a facility of 43% it was the most difficult question in this test. When studying power transmission, students should know that it is essential to minimise  $I^2R$  losses from the cables. This is done by using high voltage (to reduce the current for a given amount of power) and by employing cables of low resistance. However, the cables also need to be mechanically strong so that they will help to support their own weight. The electrical good conductors such as copper and aluminium tend to be mechanically weak, so in practice the cables are reinforced by incorporating a stronger material. 37% of the students thought that the principal reason for the steel core was that it would reduce the power lost from the cables (distractor C).